

# User Manual

## Small Keyboards

Version 02

User Manual Small Keyboards

UM022\_02, 21.05.2007

Copyright © CUE, a.s., Praha, Czech Republic 1990 - 2007.

All rights reserved. Specifications are subject to change without prior notice.

# Table of Contents

<b>1. Introduction</b> .....	<b>4</b>
1.1. Overview .....	4
1.2. Models .....	4
1.3. Features .....	4
1.4. Programming .....	4
<b>2. Front Panel</b> .....	<b>5</b>
<b>3. Button Labels</b> .....	<b>6</b>
<b>4. Addressing</b> .....	<b>7</b>
4.1. Addressing of keyboardCUE-S (serial number up to CS0174.0128) and keyboardCUE-S /w .....	7
4.2. Addressing of keyboardCUE-S (serial number CS0174.0129 and above) .....	8
4.2.1. Setting-up of ADDRESS .....	9
4.2.2. Troubleshooting .....	9
4.2.3. Display ADDRESS .....	9
4.2.4. Display Firmware version .....	9
<b>5. Mounting</b> .....	<b>10</b>
5.1. keyboardCUE-S .....	10
5.2. keyboardCUE-S /w .....	10
<b>6. Connecting</b> .....	<b>11</b>
6.1. keyboardCUE-S .....	11
6.2. keyboardCUE-S /w .....	11
<b>7. Specifications and Mechanical Drawings</b> .....	<b>12</b>
7.1. keyboardCUE-S .....	12
7.2. keyboardCUE-S /w .....	13
<b>8. Software and Firmware License</b> .....	<b>14</b>
<b>9. Warranty Conditions</b> .....	<b>15</b>
<b>10. CE Declaration of Conformity</b> .....	<b>16</b>
<b>11. FCC</b> .....	<b>17</b>

# 1. Introduction

## 1.1. Overview .....

The elegant and innovative wired keyboardCUE-S is a tabletop programmable control panel that is available in varieties of solid wood finishes with stainless steel trim. The keyboardCUE-S provides 8 buttons supported with backlighting and user changeable button labels that can be directly printed on a laser printer and inserted into the switch caps. The full-function console keyboard may be used as a dedicated wired controller for audio, video and environmental functions.

The wired keyboardCUE-S /w is a programmable control panel device designed to be built into a table. Available in a metal enclosure, the keyboardCUE-S /w provides 8 buttons supported with backlighting. User changeable button labels can be directly printed on a laser printer and inserted into the switch caps. The full-function console keyboard may be used as dedicated wired controller for audio, video and environmental functions.

## 1.2. Models .....

Model	Product code	Description
keyboardCUE-S	CS0174	Tabletop keyboard, (8) buttons
keyboardCUE-S /w	CS0146	Built-in keyboard, (8) buttons

## 1.3. Features .....

- Backlight buttons
- Programmable feedback indication (tabletop model only)
- User changeable button labels
- Stainless steel front panel and wooden enclosure (tabletop model)
- Tabletop or built-in installation
- System connection by CUEwire

## 1.4. Programming .....

All keyboards are programmed using **Cue Director** programming tool. Control commands are described in the **Programming Manual CPL References**, chapter Keyboards.

## 2. Front Panel

The front panel is equipped with (8) buttons and (8) indication LEDs (tabletop model only) - see picture.

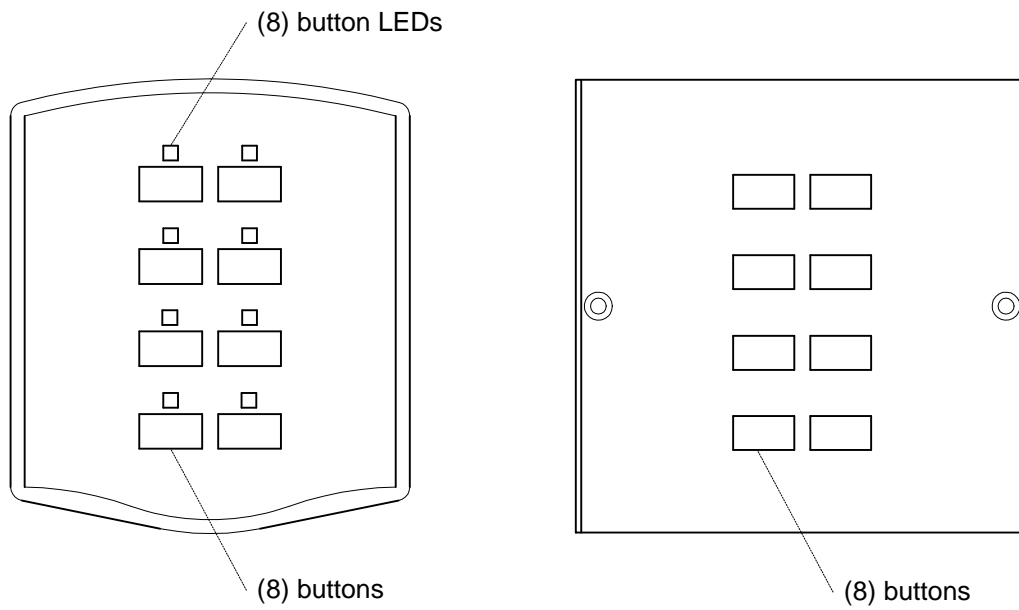

Button LEDs are controlled by special programming commands from a control unit.

## 3. Button Labels

The separate labels for each button can be printed on a transparency foil using laser or inkjet printer.

Dimension of the label are

- 6.5 mm x 12 mm for normal button
- 6.5 mm x 29 mm for double button.

It is necessary to disassembly the control panel to change a label.

Steps are

1. Put the control panel on a table face down.
2. Unscrew the screws.
3. Dismount the bottom of the control panel with electronic board.
4. Install new label.
5. Assembly the control panel.

# 4. Addressing

## 4.1. Addressing of keyboardCUE-S (serial number up to CS0174.0128) and keyboardCUE-S /w

The ADDRESS of the keyboardCUE-S and keyboardCUE-S /w can be set in the range **0 to 9** by the firmware. Standard keyboards have address 0, addresses 1 to 9 are delivered on a special order.

The BUTTON\_ID transmitted by a panel and BUTTON\_LED\_ID (tabletop model keyboardCUE-S only) are numbers used in the programming for button and bargraph identification. Both values depend on a button position and it depends on a keypad ADDRESS too. Both values are calculated according formulas

$$\text{BUTTON\_ID} = \text{Offset} + \text{Button Code}$$

$$\text{BUTTON\_LED\_ID} = \text{Offset} + \text{Button Code}$$

$$\text{Offset} = 32 * \text{ADDRESS}$$

The lowest BUTTON\_ID is generated by a button in the upper left corner the highest BUTTON\_ID is generated by a button in the lower right corner - see example for ADDRESS = 0 on the picture below.

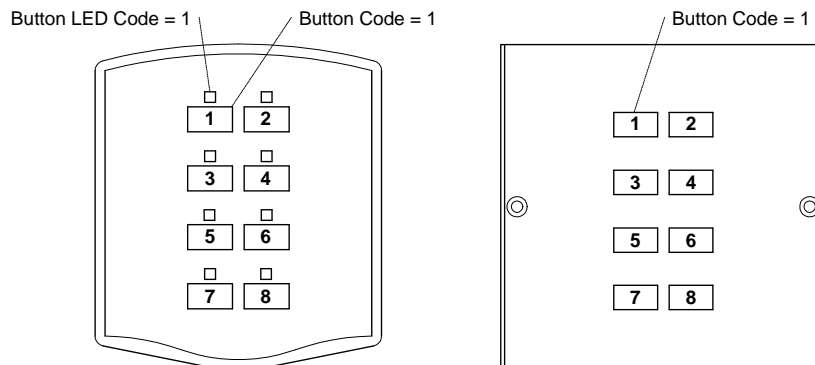

In the table below there is Button ID range for each address.

ADDRESS	BUTTON_ID range = BUTTON_LED_ID range	
0	1	8
1	33	40
2	65	72
3	97	104
4	129	136
5	161	168
6	193	200
7	225	232
8	257	264
9	289	296

## 4.2. Addressing of keyboardCUE-S (serial number CS0174.0129 and above)

The ADDRESS of the keyboardCUE-S can be set in the range **0 to 255**. Default keyboard ADDRESS is 0.

The BUTTON\_ID transmitted by a panel and BUTTON\_LED\_ID (tabletop model keyboardCUE-S only) are numbers used in the programming for button and bargraph identification. Both values depend on a button position and it depends on a keyboard ADDRESS too. Both values are calculated according formulas

$$\text{BUTTON\_ID} = \text{Offset} + \text{Button Code}$$

$$\text{BUTTON\_LED\_ID} = \text{Offset} + \text{Button Code}$$

$$\text{Offset} = 32 * \text{ADDRESS}$$

The lowest BUTTON\_ID is generated by a button in the upper left corner the highest BUTTON\_ID is generated by a button in the lower right corner - see example for ADDRESS = 0 on the picture below.

Button LED Code = 1      Button Code = 1

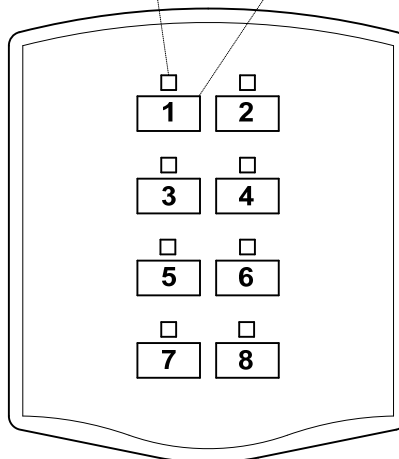

In the table below there is Button ID range for some addresses.

ADDRESS	BUTTON_ID range = BUTTON_LED_ID range	
0	1	8
1	33	40
2	65	72
...	...	...
9	289	296



### 4.2.1. Setting-up of ADDRESS

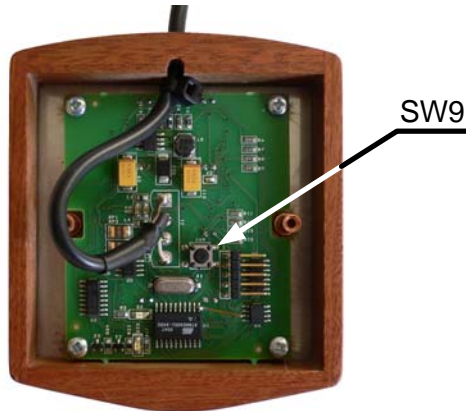

1. Unscrew two screws on bottom side of the keyboard and remove bottom cover.
2. Push switch SW9 on PCB bottom side; backlight LED's are switched Off to indicate Set Address Mode.
3. Button LED's indicate ADDRESS in binary code – Button 1 bit 0, Button 2 bit 1 etc... Push buttons to toggle address bits to requested value of ADDRESS (see examples on the picture below).
4. Push switch SW9 to save ADDRESS to non-volatile memory and to enter keyboard Standard Mode - backlight LED's are switched On to indicate Standard Mode.
5. Assembly the control panel.

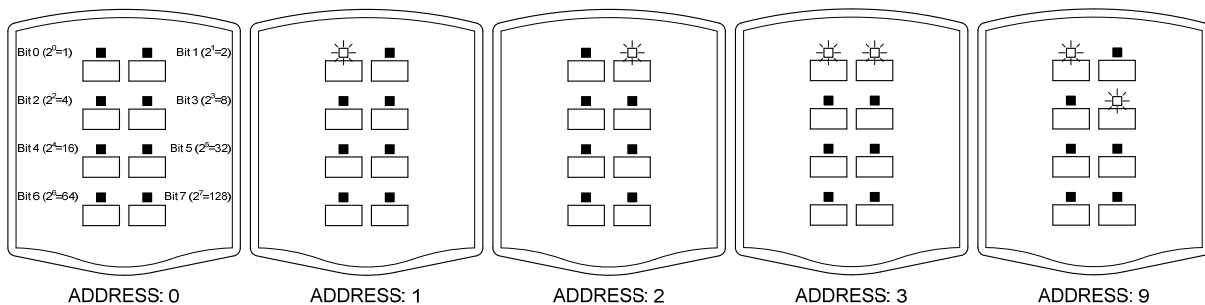

### 4.2.2. Troubleshooting

Flashing backlight LED's means non-volatile memory ERROR. Try Power OFF – Power ON sequence to restart device and set ADDRESS again.

### 4.2.3. Display ADDRESS

Press and hold Button 1 while powering On. Button LED's indicate ADDRESS in binary code – Button 1 bit 0, Button 2 bit 1, .... After 10 sec keyboard continues normal operation.

### 4.2.4. Display Firmware version

Press and hold Button 2 while powering ON. All LED's flashes 5 times – FW version 1.05. After 10 sec keyboard continues normal operation.

## 5. Mounting

### 5.1. keyboardCUE-S.....

The keyboardCUE-S is a tabletop model. There are no special mounting requests.

### 5.2. keyboardCUE-S /w .....

The keyboardCUE-S /w can be mounted to the table or to the wall box (not delivered).

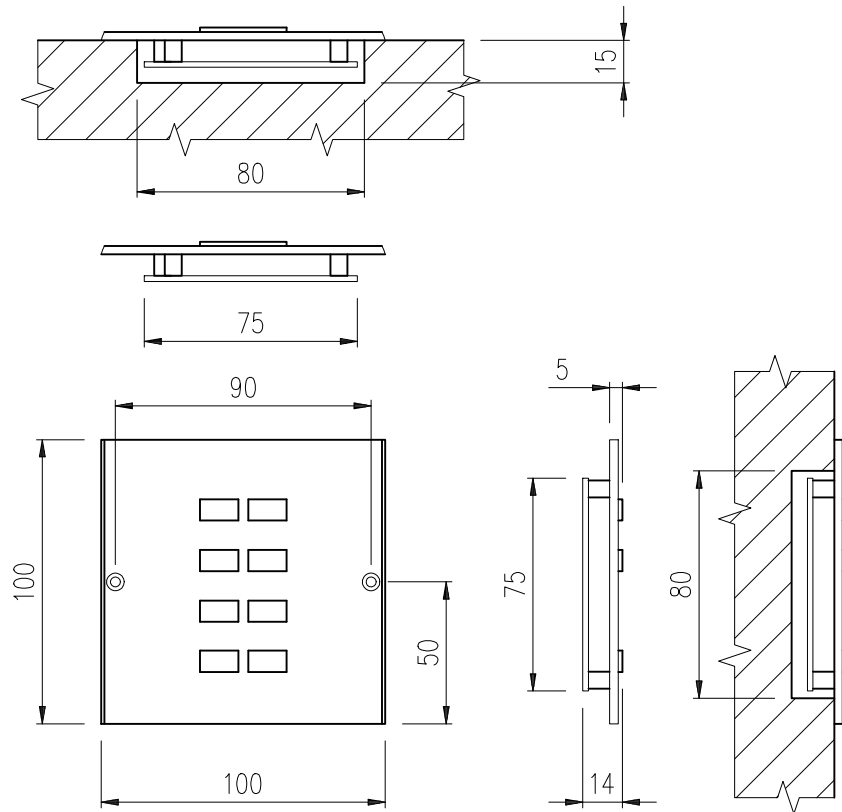

# 6. Connecting

## 6.1. keyboardCUE-S.....

This model of the keyboard is connected to the system by CUEwire. The keyboard is equipped with 3 m length or 10 m length cable with 4-pin connector. Pin connection of the CUEwire connector is described in the following table.

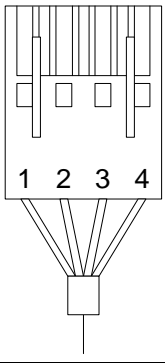
CUEwire, 4-pin connector	
	Pin 1 +24 VDC
	Pin 2 GND
	Pin 3 A+
	Pin 4 B-

## 6.2. keyboardCUE-S /w .....

This model of the keyboard is connected to the system by CUEwire.

The keyboard is equipped with 4-pin terminal which is located on the rear side of the keyboard - see picture below.

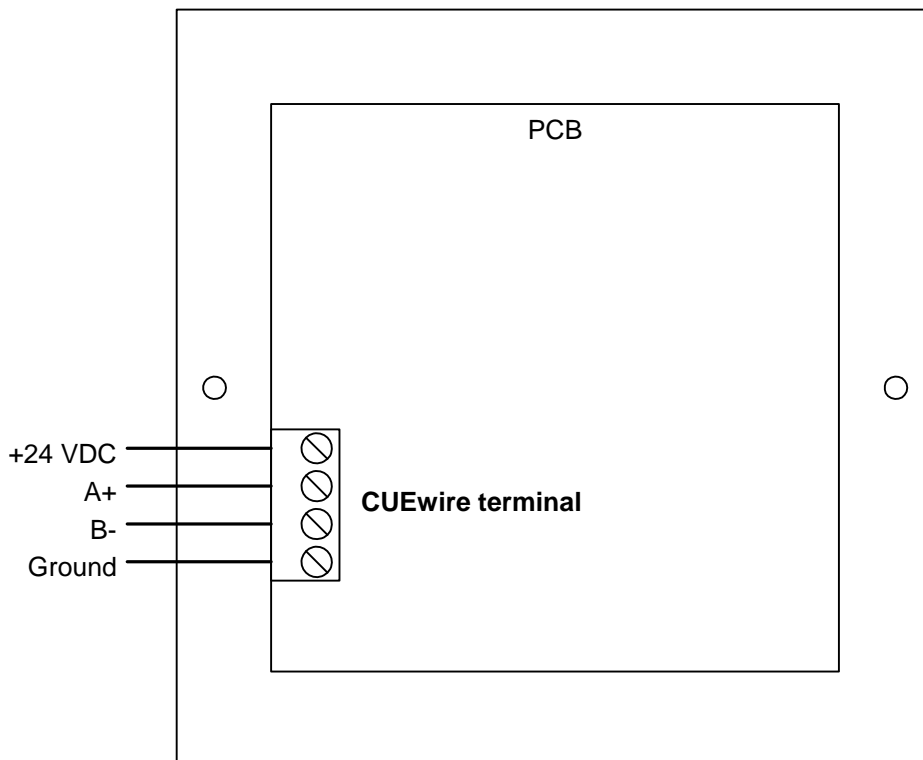

# 7. Specifications and Mechanical Drawings

## 7.1. keyboardCUE-S.....

- Buttons layout.....(8) buttons
- Indication .....(8) LEDs
- System connection .....CUEwire (RS-485), 4-pin connector
- Power supply .....24 VDC (+/- 20%), 3 W
- Enclosure.....Wood - stainless steel panel
- Dimensions (WxHxD) .....86 mm (3.4") x 98 mm (3.9") x 27 mm (1.1")
- Weight.....0.4 kg / 1.1 lb

All dimensions are in mm.

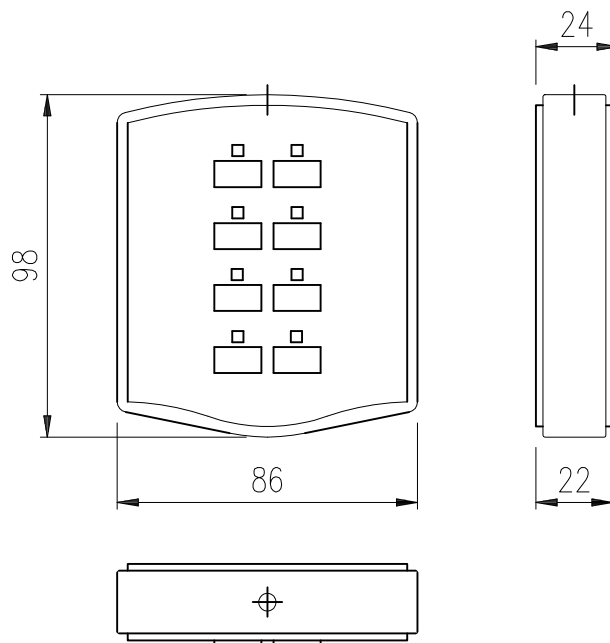

## 7.2. keyboardCUE-S /w .....

- Buttons layout.....(8) single buttons or (4) double buttons
- System connection .....CUEwire (RS-485), screw terminals
- Power supply .....24 VDC (+/- 20%), 3 W
- Enclosure.....Metal, black panel
- Dimensions (WxHxD) .....100 mm (3.9") x 100 mm (3.9") x 30 mm (1.2")
- Weight.....0.15 kg / 0.4 lb

All dimensions are in mm.

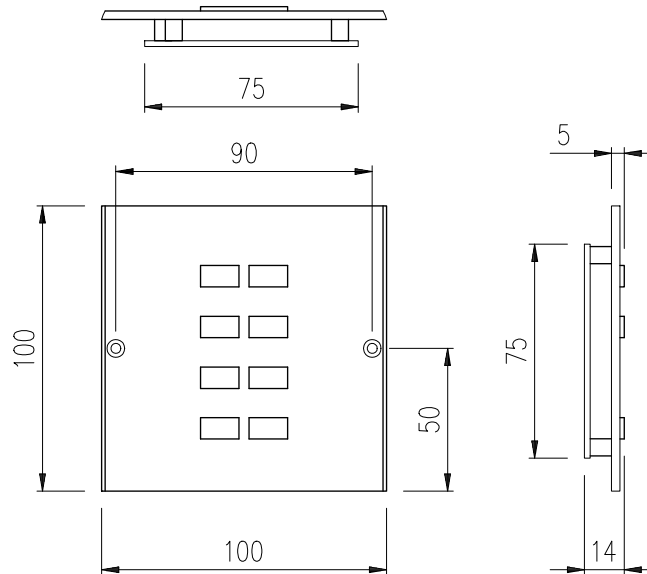

## 8. Software and Firmware License

END-USER NOTICE AND LICENSE AGREEMENT FROM CUE, spol. s r.o.

### NOTICE TO END-USER

CAREFULLY READ THE FOLLOWING LEGAL AGREEMENT (THIS "LICENSE"). INSTALLATION OR USE OF THE ENCLOSED CUE, spol. s r.o. SOFTWARE PROGRAMS (COLLECTIVELY, "SOFTWARE") ON YOUR COMPUTER SYSTEMS OR HARDWARE DEVICES CONSTITUTES YOUR ACCEPTANCE OF THESE TERMS. IF YOU DO NOT AGREE TO THE TERMS OF THIS LICENSE, PROMPTLY DELETE THE SOFTWARE FROM YOUR COMPUTER SYSTEMS AND HARDWARE DEVICES, DESTROY ANY COPIES YOU MADE OF THE SOFTWARE OR ANY INSTALLATION MEDIA OF THE SOFTWARE INCLUDED WITH YOUR SYSTEM, AND DISPOSE OF ALL WRITTEN MATERIALS IN YOUR POSSESSION REGARDING THE SOFTWARE.

### License Grant

CUE grants to You, as an individual, a license to install and use one (1) copy of the Software on a single computer at a time; provided, however, that You may make copies of the Software solely for Your development of applications for CUE hardware and demonstration versions of such applications. Any applications created with the Software may only be used with Cue hardware. Your license to use the Software is conditioned upon Your compliance with the terms of this License. A License is required for each end-user of the Software. A license is required for each installation of the Software. You may make one (1) copy of the Software for archival purposes only. You may use this Software only in connection with CUE hardware. You must have acquired the Software directly in connection with the purchase of CUE hardware from CUE or from a CUE approved reseller for this license to be effective. If You have purchased a Site License, You may complete only the number of installations specified in the License Agreement accompanying the Software.

### Copyright

The Software and software built into CUE hardware ("Firmware") are protected by copyright law and international treaty provisions. You acknowledge that no title to the intellectual property in the Software and Firmware is transferred to You. You further acknowledge that title and full ownership rights to the Software and Firmware will remain the exclusive property of CUE, and You will not acquire any rights to the Software and Firmware except as expressly set forth in this License. You agree that any copies of the Software will contain the same proprietary notices which appear on and in the Software.

### Prohibited Uses

Without obtaining prior written permission from CUE, You may not (a.) use, copy, modify, alter, or transfer the Software or documentation except as expressly provided in this License; (b.) translate, disassemble, decompile, reverse program or otherwise reverse engineer the Software and Firmware; (c.) sublicense or lease the Software or its documentation (d.) use this Software with any hardware other than products produced by CUE or in connection with applications being developed for CUE hardware; or (e.) use the Software in a multi-user, network, or multiple computer environment or in a rental, time sharing or computer service business. Without prejudice to any other rights, CUE may terminate this License if You fail to comply with its terms and conditions. In such event, You must immediately destroy all copies of the Software.

### No Other Warranties

CUE DOES NOT WARRANT THAT THE SOFTWARE AND FIRMWARE IS ERROR FREE. CUE DISCLAIMS ALL WARRANTIES WITH RESPECT TO THE SOFTWARE AND FIRMWARE, EITHER EXPRESS OR IMPLIED, INCLUDING BUT NOT LIMITED TO IMPLIED WARRANTIES OF MERCHANTABILITY, FITNESS FOR A PARTICULAR PURPOSE AND NONINFRINGEMENT OF THIRD PARTY RIGHTS. SOME JURISDICTIONS DO NOT ALLOW THE EXCLUSION OF IMPLIED WARRANTIES OR LIMITATIONS OF HOW LONG AN IMPLIED WARRANTY MAY LAST, OR THE EXCLUSION OF LIMITATION OF INCIDENTAL DAMAGES, SO THE ABOVE LIMITATIONS OR EXCLUSIONS MAY NOT APPLY TO YOU. THIS WARRANTY GIVES YOU SPECIFIC LEGAL RIGHTS AND YOU MAY ALSO HAVE OTHER RIGHTS WHICH VARY FROM JURISDICTION TO JURISDICTION.

### No Liability for Consequential Damages

IN NO EVENT SHALL CUE BE LIABLE TO YOU FOR ANY CONSEQUENTIAL, SPECIAL, INCIDENTAL, OR INDIRECT DAMAGES OF ANY KIND ARISING OUT OF THE PERFORMANCE OR USE OF THE SOFTWARE, EVEN IF CUE HAS BEEN ADVISED OF THE POSSIBILITY OF SUCH DAMAGES.

### Label on Hardware

Use of this hardware and the software programs controlling this hardware is subject to the terms of the Software and Hardware License Agreements (the "License Agreements"). You should not use the software and hardware until you have read the License Agreements. By using the software and hardware, you signify that you have read the Licenses Agreements and accept their terms. The "License Agreement" is available at [www.cuesystem.com](http://www.cuesystem.com).

### Trademark Notice

CUE and the CUE logo are trademarks of CUE spol. s r.o. in the United States and in other countries.

# 9. Warranty Conditions

## Warranty Duration

CUE provides warranty for all CUE products for a period of 3 years from the day of purchase. The provided warranty for touch screens is 2 years from the day of purchase. CUE accepts reclamation of 5 not properly working dots and more (2 dots join – 1 counts). The warranty provided for rechargeable accumulators is 6 months from the day of purchase

## Liability

CUE is not liable for any consequential damage caused by CUE products including any loss of profits, incidental or consequential damages or any claims made by a third parties.

## General Warranty Terms

- a) CUE warrants that its products are without defects in material and are fully functional for the duration of the warranty.
- b) Warranty repairs are free of charge. The customer will send the damaged device to CUE at his cost.
- c) All warranty repairs and after warranty services are made at CUE premises. It is strictly prohibited to repair CUE products or to change any accessory parts, except those parts with limited service life. CUE is not liable for consumables or parts with limited service life (lamps, batteries etc.)
- d) The warranty further does not apply to the following cases
  - Damages caused by operating the system not according to the conditions defined in user manual or instruction (wrong power supply voltage, operation outside deferred temperature range, operation in humid environment and mechanical damages).
  - Damages caused by faulty service, maintenance, connection, and use of other than original connection cable.
  - Damage caused by agencies i.e. incidental or unpredictable impacts (fire, earthquake, flood, thunder, strong electric induction, water, strong wind, theft, vandalism etc.)

## After Warranty Services

- a) All warranty repairs are normally on a 'back to base' basis, as defined in 3 c)
- b) All out warranty repair costs will be fully charged to the customer.
- c) In cases where our staff are called out to assist, cost of transport and time will be at customer cost

# 10. CE Declaration of Conformity



## CE Declaration of Conformity

We, the producer **CUE, a.s.**, K Nouzovu 6, Praha 4, Czech Republic acknowledge our sole responsibility, that the product including accessories

**Kind of equipment:** Remote Control System

**Type designation**  
(in alphabetical order)

airCUE-XM8	CS0254-W, CS0254-O, CS0254-M	PED202	CS0165-1, CS0165-2
airCUE-XM8 Docking Station	CS0260-W, CS0260-O, CS0260-M	PEF150	CS0249-1, CS0249-2
analogCUE	CS0004	PEF200	CS0166-1, CS0166-2
auxCUE	CS0005	PER610	CS0167-1, CS0167-2
Back box L	CS0238-MB	PES03	CS0168
Back box M	CS0239-MB	PET102	CS0244-1, CS0244-2
Back box S	CS0241-MB	PET105	CS0245-1, CS0245-2
CUEadapter /10W	CS0184-E, CS0184-U	powerAUX	CS0016
CUEadapter /20W	CS0226-E, CS0226-U	PowerPacket	ST0026-1, ST0026-2
CUEadapter /50W	CS0185-E, CS0185-U	Rack mount panel L	CS0238-MR
CUEadapter /80W	CS0186-E, CS0186-U	Rack mount panel M	CS0239-MR
CUEwire Converter 232/422/485	CS0233	Rack mount panel S	CS0241-MR
eCUE	CS0173	rfbaseCUE	CS0171-4, CS0171-8, CS0171-9
Elite-A-M	ST0019	rfCUE 99	CS0170-*4A, CS0170-*8A, CS0170-*9A
Elite-A-XM8	ST0018-W, ST0018-O, ST0018-M	sbicCUE-DMX	CS0201
Elite-B-S	ST0020	sensorCUE	CS0265
Elite-B-SRF	ST0021-4, ST0021-8, ST0021-9	smartCUE	CS0008-R, CS0008-M
Elite-D-LV	ST0025	soundCUE	CS0009
Elite-D-M	ST0024	touchCUE-L	CS0236
Elite-G-S /b	ST0022	touchCUE-L /b	CS0238
Elite-G-SX /b	ST0023	touchCUE-L 99	CS0234-W, CS0234-O, CS0234-M
inputCUE	CS0191	touchCUE-LV	CS0236-V
ipCUE-alpha	CS0251	touchCUE-LV /b	CS0238-V
ipCUE-beta	CS0252	touchCUE-LV 99	CS0234-W-V, , S0234-O-V, CS0234-M-V
ipCUE-delta	CS0267	touchCUE-M	CS0237
ipCUE-epsilon	CS0268	touchCUE-M /b	CS0239
ipCUE-gamma	CS0253	touchCUE-M 99	CS0235-W, CS0235-O, CS0235-M
irCUE 99	CS0149-WA, CS0149-OA, CS0149-MA	touchCUE-MV	CS0237-V
irCUE Receiver 485	CS0169-C	touchCUE-MV /b	CS0239-V
keyboardCUE 99	CS0145-W, CS0145-O, CS0145-M	touchCUE-MV 99	CS0235-W-V, CS0235-O-V, CS0235-M-V
keyboardCUE-S	CS0174-W, CS0174-O, CS0174-M	touchCUE-S	CS0247
keypadCUE-1G	CS0221	touchCUE-S /b	CS0241
keypadCUE-2G	CS0222	touchCUE-S 99	CS0248-W, CS0248-O, CS0248-M
keypadCUE-3G	CS0223	touchCUE-SRF	CS0188-4, CS0188-8, CS0188-9
monitorCUE	CS0203-W, CS0203-O, CS0203-M	touchCUE-SX /b	CS0266
PEA208	CS0225-1, CS0225-2	touchCUE-V /i	CS0190
PEC25	CS0163	touchCUE-XL 99	CS0261-W, CS0261-O, CS0261-M
PED108	CS0164-1, CS0164-2	touchCUE-XLV 99	CS0261-W-V, CS0261-O-V, CS0261-M-V

in accordance with EMC Directive 89/336/EEC,  
is in compliance with the following norms or documents:

EN50082-1 (IEC801-2), IEC65(CO)39, DIN VDE 0839 part 82-1, DIN VDE 0843 part 4, IEC801-4, EN50081-1, EN55022 class B, DIN VDE 0839 part 81-1, EN55014, EN55011.

1.1.2007

Jaroslav Dibitzl  
Member of Board of Directors



# 11. FCC

## Caution

Changes or modifications to this unit not expressly approved by the party responsible for compliance could void the user's authority to operate the equipment.

## Note

This equipment has been tested and found to comply with the limits for a Class B digital device, pursuant to Part 15 of the FCC Rules. These limits are designed to provide reasonable protection against harmful interference in a residential installation. This equipment generates, uses and can radiate radio frequency energy and, if not installed and used in accordance with the instructions, may cause harmful interference to radio communications. However, there is no guarantee that interference will not occur in a particular installation. If this equipment does cause harmful interference to radio or television reception, which can be determined by turning the equipment off and on, the user is encouraged to try to correct the interference by one or more of the following measures:

- Reorient or relocate the receiving antenna.
- Increase the separation between the equipment and receiver.
- Connect the equipment into an outlet on a circuit different from that to which the receiver is connected.
- Consult the dealer or an experienced radio / TV technician for help.

